

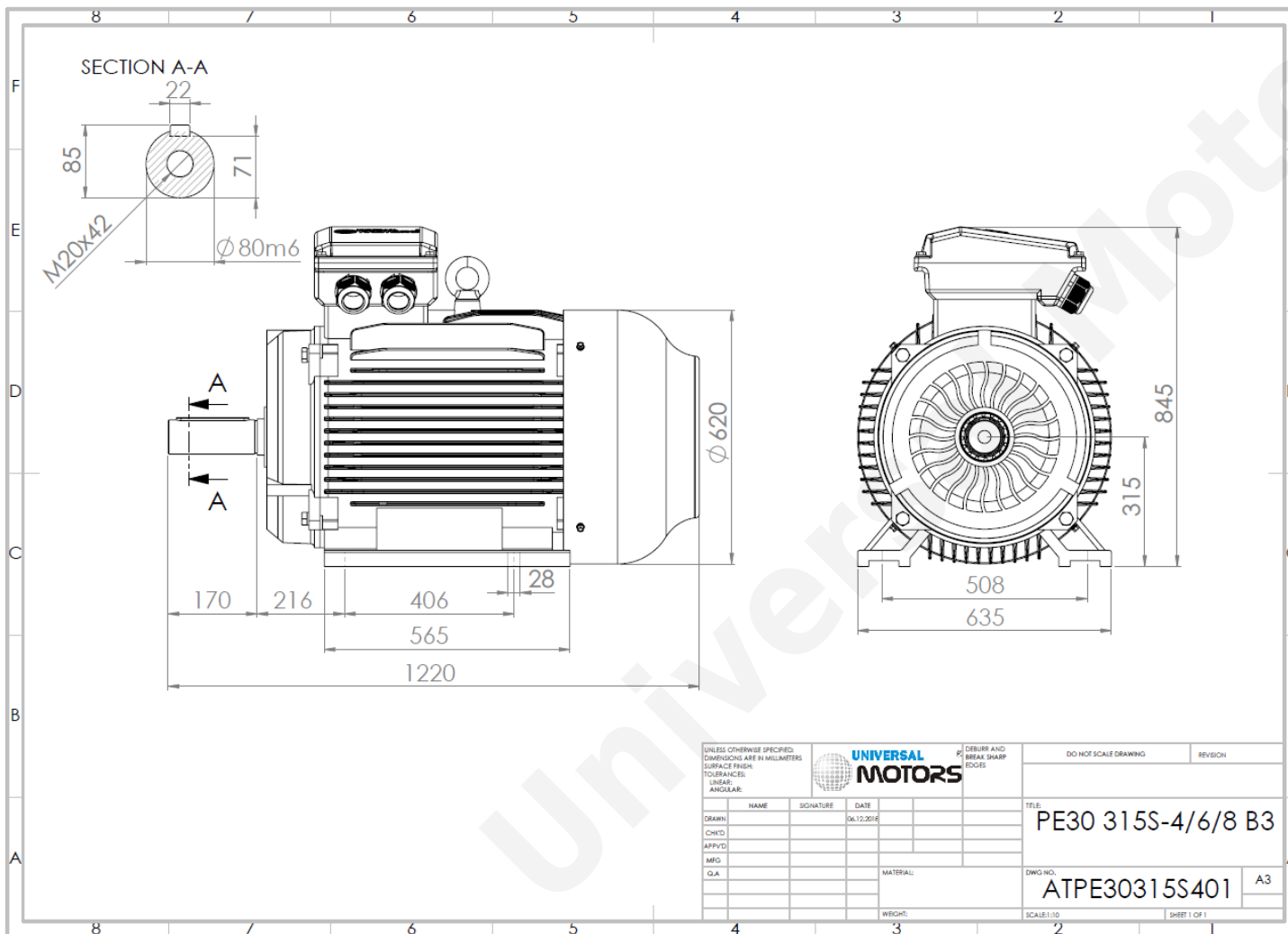

TECHNICAL DATA

Three Phase Electric Motors - Cast Iron Frame
 PE30 315S-8
 55 kW / 75 Cv
 735 RPM



Motor type:	PE30 315S-8
Output:	55 kW / 75 Cv
Speed (min ⁻¹):	735 RPM
Frequency:	50 Hz
Voltage:	400 V
Current:	106.0 A
Power factor (Cos ϕ):	0.81
Poles:	8
Insulation class:	F
Temperature rise Class:	B
Efficiency 50%:	91.5 %
Efficiency 75%:	93.0 %
Efficiency 100%:	92.5 %
Torque:	713 N.m
Tstarting/Tnominal:	1.8
Istarting/Inominal:	6.6
Tmaximum/Tnominal:	2.0
Noise:	82 Db(A)
Weight:	980 Kg
Bearing DE:	NU 319
Bearing NDE:	6319 C3

Regime - S1

Altitude - 1000m

Environment Temperature - 40°C

CONTACTS:

UNIVERSAL MOTORS Tel: +351 252 299 080
 Rua de São Brás, 745 Fax: +351 252 299 089
 4480-782 VILA DO CONDE Mail: geral@universalmotors.pt

* References applied only in the UK